

USER MANUAL

PALAX® C1000

Tractor drive
Electrical drive



SERIAL NUMBER AND YEAR OF MANUFACTURE _____

PALAX®

Lahdentie 9
FI-61400 Ylistaro, FINLAND
Tel. +358 6 474 5100
palax.fi

CONTENTS

1	Basic information and responsibilities.....	4
---	---	---

1.1	Introduction	4
1.2	EU declaration of conformity	5
1.3	Purpose of use	6
1.4	Warning symbols.....	6
1.5	Type plates.....	8
1.6	The machine's main measurements and models	8
1.7	Safety instructions.....	8
1.8	Noise and vibration	10
1.9	Operator's responsibilities	10
1.10	Operating conditions.....	10
1.10	Guarantee terms.....	11
2	Receipt and assembly of the machine.....	12
2.1	Lifting the machine.....	12
2.2	Delivery of the machine and unloading the delivery.....	12
2.3	Delivery inspection.....	13
2.4	Main components of the machine	13
3	Preparing the machine for operation and transport.....	15
3.1	Extension.....	15
3.2	Adjusting the cutting length limiter.....	15
3.3	Placing the conveyor in working position	15
3.4	Placing the conveyor in transport position	17
4	Tractor drive.....	17
4.1	Installation.....	18
4.2	Emergency stop for a tractor-powered machine.....	19
4.3	Operation in an emergency	20
4.4	Moving the machine using a transport chassis (figure 18).....	21
5.	Description of the function of the firewood processor	22
5.1	Electrical drive, starting and emergency stop.....	22
5.2	Controlling the machine	22
5.3	Using the firewood processor, sawing wood	22
5.4	Using the cutting blade, before sawing.....	23
5.5	During sawing.....	23
5.6	Setting log on the table	23
5.7	Sawing logs.....	23
5.8	Sawing the last log.....	24
5.9	Feeding the last log for splitting	24
5.10	Disturbances in sawing and solving them	24
6.	Using the firewood processor, splitting wood	25
6.1	Splitting cylinder	25
6.2	Splitting blades	25
6.3	Splitting blade height adjustment	25
6.4	Disturbances in splitting and solving them.....	25
6.5	Safely resplitting logs.....	26

7	Machine maintenance	27
7.1	Replacing the cutting blade, figure 21	27
7.2	Sharpening the blade, hard-metal blade	27
7.3	Tensioning the blade, hard-metal blade	28
7.4	V-belt tensioning, angle transmission/middle shaft	28
7.5	V-belt tensioning, middle shaft/blade shaft V-belt tensioning	28
7.6	Replacing V-belts, angle transmission/middle shaft.....	28
7.7	Replacing V-belts, middle shaft/blade shaft	28
7.8	Tightening the input conveyor belt	29
7.9	Replacing the input conveyor belt, figure 23	29
7.10	Changing the oil of the angle transmission	30
7.11	Changing hydraulic oil.....	30
7.12	Lubrication of the machine	30
7.13	Tensioning the conveyor chain of the conveyor	31
7.14	Cleaning the conveyor	31
7.15	Washing the machine	31
7.16	Storage of the machine.....	31
8	Maintenance table.....	32
9	Failures and remedial measures	33
10	Electrical diagrams.....	34

BASIC INFORMATION AND RESPONSIBILITIES

1.1 Introduction

This manual is intended for operators with the appropriate expertise. The operator is required to have the general knowledge and skills needed in normal situations. For example, a person purchasing a tractor-powered machine is expected to be able to operate the tractor's cardan shaft drive.

Study the manual thoroughly before installing the machine and beginning operation. In addition, familiarise yourself with the controls and the emergency stop mechanism before operating the machine. Additional information on our company's products is available on our website at www.palax.fi.

NOTE! Always keep this manual in the immediate vicinity of the machine.

1.2 EU declaration of conformity

Directive 2006/42/EC

Manufacturer: TP Silva Oy
www.palax.fi
Lahdentie 9
FI-61400 Ylistaro
Finland
+358 6 474 5100

Person responsible

for the technical file: Kai Koskela, kai.koskela@palax.fi

Product: Palax C1000

Firewood processor with 4.3-metre out-feed conveyor

Driving power: Tractor output, electric motor

Model markings: TR Tractor-powered with internal hydraulics
EM Electric motor powered

Machine serial number: _____

We hereby declare that this machine meets the requirements concerning the safety of machinery specified in Government Decree 12 June 2008/400, which was instituted to bring into force Machinery Directive 2006/42/EC, and that the following harmonised standards have been applied in the design of the machine:

SFS MANUAL 93 series, SFS-EN 349-1+A1, SFS-EN 609-1+A1, SFS-EN 618, SFS-EN 620, SFS-EN 847-1+A1, SFS-EN 847-2+A1, SFS-EN 847-3, SFS-EN 953+A1, SFS-EN 954-1, SFS-EN 982+A1, SFS-EN 1870-3+A1, SFS-EN 4254-1, SFS-EN 11684, SFS-EN 12100-1+A1, SFS-EN 12100-2, SFS-EN 13850, SFS-EN 13857, SFS-EN 14121-1, ISO/TR 14121-2, SFS-EN 60204-1+A1.

TP Silva Oy
1.6.2020



Jori Lammi
Managing Director

1.3 Purpose of use













This firewood processor with conveyor is intended for making firewood from round timber. Using the machine for other purposes is not allowed.

Max dimensions of the wood

Cutting power, maximum log diameter approx. 40 cm.

Maximum length of the wood to be cut is 4–6 m, depending on the infeed table in use.

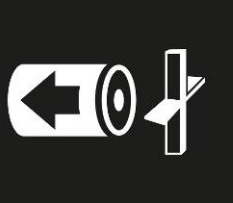
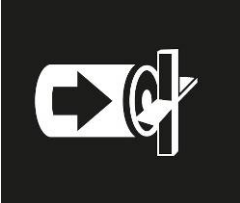
1.4 Warning symbols

			
<p>Use sufficiently tight-fitting work clothing Wear eye and ear protection Wear safety footwear Wear work gloves</p>			
			
<p>Lifting point</p>	<p>The cutting blade must be in the upper position to enable opening the guard mesh of the splitting channel</p>		
			
<p>Lubrication point</p>	<p>Blade rotation direction</p>	<p>EMERGENCY STOP (EM)</p>	<p>Cardan shaft rotation direction</p>
			
<p>Stop splitting</p>	<p>Activate splitting</p>	<p>Conveyor safety distance</p>	

<p>Cardan shaft rpm range</p>	<p>Lifting point</p>	<p>Beware of the cardan shaft.</p>	<p>Read the machine's manual</p>
<p>Beware of the rotating blade</p>	<p>Stay clear of the moving parts of the machine</p>	<p>Detach the power source of the machine before any maintenance operations</p>	<p>Only one person may operate the machine</p>
<p>Input conveyor reverse, Sawing, Input conveyor feeding</p>			<p>Stopping operation by loosening the V-belts</p>
<p>Ensure that the wood is not transferred to cutting in upright position</p>		<p>Cutting length adjustment</p>	

- The explanations of the markings for the machine control functions are discussed in chapter 2.4 Main components of the machine, on pages 13 and 14 of the user manual. Figures 4 and 6.

1.5 Type plates

The machine's type plate

- Name and address of manufacturer.
- Machine type.
- Machine weight TR 1,780 kg, EM 1,850 kg.
- Diameter of the cutting blade 1,000 mm, opening 40 mm.
- Maximum rotation speed 1,000 rpm.
- Hydraulics, Max 210 bar
- Production number and year.

The machine's type plate is on the infeed table end of the machine.

Type plate for electrical drive

- 3-phase motor
- Voltage 230/380 V or 380/600 V, may vary depending on country.
- Power 15 kW.
- Current 35A.

1.6 The machine's main measurements and models

Model	C1000	
Driving power	TR	EM
Weight	1,780 kg	1,850 kg
Height/width/length	Transport position 2.55 m/1.75 m/3.2 m	
Input conveyor	Length 2.4 m Height 0.9 m	
Diameter of the blade/opening	1,000 mm/40 mm	
Max rpm of the blade	1,000 rpm	
Max log diameter	Max log diameter in cutting 40 cm	
Max/min log length	Max log length in cutting 55 cm	

- The 4.3-metre output conveyor is included in the weight.

1.7 Safety instructions

General provisions and restrictions

- Max length of log in cutting 4 metres, if log deck is not used.
- The machine has been designed solely for making firewood.
- Only one person may operate the machine.
- When the machine is transported on public roads, it must be equipped with additional lights.
- Danger zone of the conveyor 5 metres around and away from the conveyor.
- Lift and lock the infeed table and output conveyor in their transport position for the duration of the transportation.
- Only people over 18 may operate the machine.
- Do not remove any safety devices from the machine.

Operator

- Every machine operator must read the entire manual thoroughly.
- Always use eye protection and hearing protection.
- Always use safety footwear.
- Always use work gloves.
- Do not wear loose or hanging clothing.

Before use

- Always prepare the machine and conveyor carefully for use before starting the machine.
 - Ensure that no unauthorised persons are in the working area.
 - Ensure that the cardan shaft is undamaged and attach the shaft guard chain in its place. The allowed rpm range of the cardan shaft is 450–480 rpm.
 - Operate the machine on a sufficiently solid and even surface.
 - Only use the machine with sufficient lighting.
 - For tractor-powered machines, ensure that one drawbar is attached, and ensure sufficient space for the cardan shaft and its guard.
 - Always check that all the guards and covers are undamaged and attached.
 - Always check that the cutting blade is undamaged.
 - Always check the condition of the power cables.
 - Always check the operation of all control equipment.
 - Always check that the machine has a sufficient amount of oil and that the hydraulic hoses and components are undamaged.
 - Ensure that the machine is standing firmly in place before starting operation.
- **During operation**
 - Careless sawing may cause severe hazard!
 - When sawing, ensure that the sawing point of the log corresponds to the cutting table support roll, as incorrect placement may cause the log to spin, causing damage.
 - Be careful when sawing logs with branches or turns, as incorrect sawing may cause the log to spin or bend the blade, causing it to break.
 - Keep the working area clear of unnecessary items.
 - Always stop the machine and disconnect the supply cable or cardan shaft before conducting maintenance.
 - Only saw one log at a time.
 - Danger! Stay clear of moving parts.

1.8 Noise and vibration

The A-weighted sound pressure level at the working location is 88 dB (A), and the sound power level

102 dB (A). The vibration values do not exceed 2.5 m/s².

1.9 Operator's responsibilities

- The machine may only be used for making firewood.
- **All of the machine's safety devices are necessary** for ensuring a sufficient level of safety.
- The Palax C1000 is a very safe machine when it is operated according to the instructions, the maintenance operations are carried out regularly, and it is used carefully.
- **The machine's operator is responsible** for making sure that the safety devices are undamaged and that the machine has been adequately serviced before commencing operation.
- The operator is responsible for ensuring that the machine does not cause danger to others.
- Altering the machine's structure is prohibited.
- Using the machine while under the influence of alcohol or drugs is prohibited.
- Keep in mind that the operator is responsible for any accidents that may occur if safety devices have been removed from the machine.

1.10 Operating conditions

- Always place the machine as level as possible.
- Organise the environment so as to minimise any danger, such as a risk of slipping in winter.
- When starting the machine in extremely cold weather, the machine should be run at approximately 1/4 of the maximum rpm for 5–10 minutes in order to warm the oils up and make them move easier.
- Only use the machine with sufficient lighting.
- It is recommendable to acquire or build a suitable rack for the logs to be processed, which will allow them to be on the level of the infeed table of the firewood processor. This minimises any unnecessary lifting and makes the work considerably faster. We recommend using the Palax Mega or Palax Midi log tables.
- The optimal operating temperature range is approximately -20...+30 degrees C. There are no restrictions in regard to weather conditions.
- Make sure that there are no children or unauthorised persons in the working area.
- Never operate the machine indoors, as the dust and exhaust gases may cause a hazardous situation.

1.10 Guarantee terms

The guarantee period is 12 months from the purchase date of the machine.

The guarantee covers

- Parts damaged in normal use due to faults in the material or workmanship.
- Reasonable repair expenses in accordance with the agreement between the seller or buyer and the manufacturer.
- Faulty parts will be replaced with new ones.

The guarantee does not cover

- Damage resulting from normal wear and tear, improper use or neglecting maintenance.
- The cutting blade, input belt, V-belts, or oils.
- Defects in a machine to which the buyer has carried out or commissioned changes to the degree that the machine can no longer be considered equivalent to the original machine.
- Other potential costs or financial obligations resulting from the procedures mentioned above.
- Indirect costs and/or travel costs resulting from guarantee repairs.
- The guarantee for parts replaced during the guarantee period of the machine expires at the same time as the machine's guarantee.

2 RECEIPT AND ASSEMBLY OF THE MACHINE

2.1 Lifting the machine

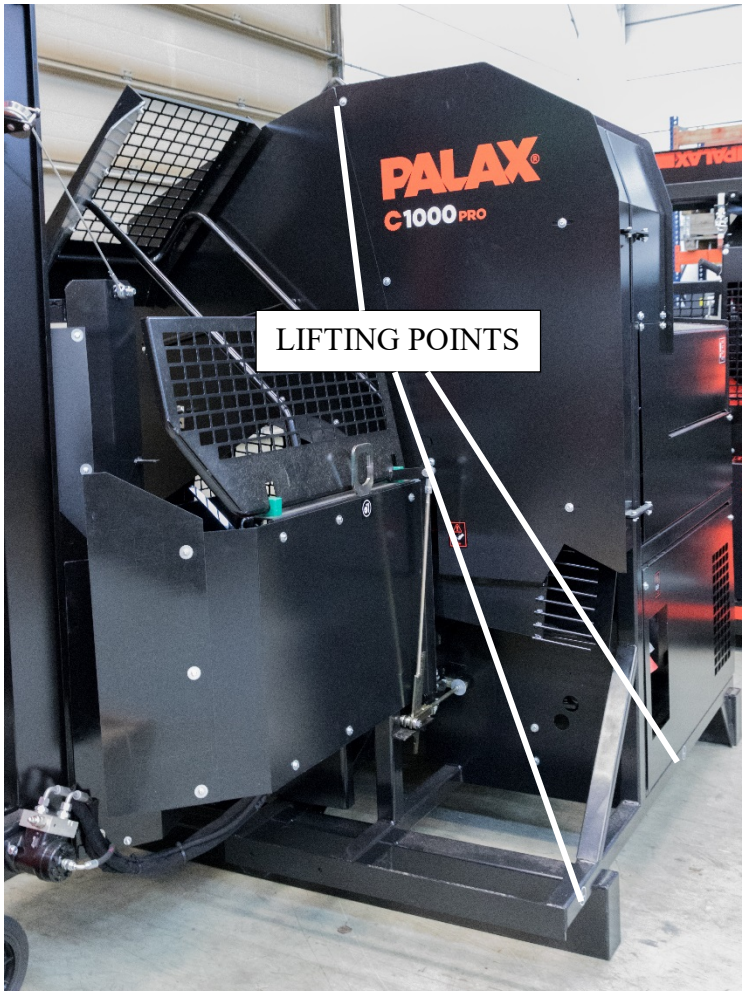

Figure 1

The machine can be lifted on both sides using a forklift. The body of the machine is equipped with guide rails for the forks of the forklift. The machine can also be lifted using the lifting lug on the upper part of the machine's body.

2.2 Delivery of the machine and unloading the delivery

- The machine is delivered almost fully assembled, with the conveyor attached.
- The output conveyor extension and the firewood conveyor are in their transport positions.
- The angle gear is equipped with gear oil.

2.3 Delivery inspection

- Inspect the delivery immediately.
- In case of any damage caused during transport, enter the damage in the consignment note and contact the driver and the company that sold the product.

2.4 Main components of the machine

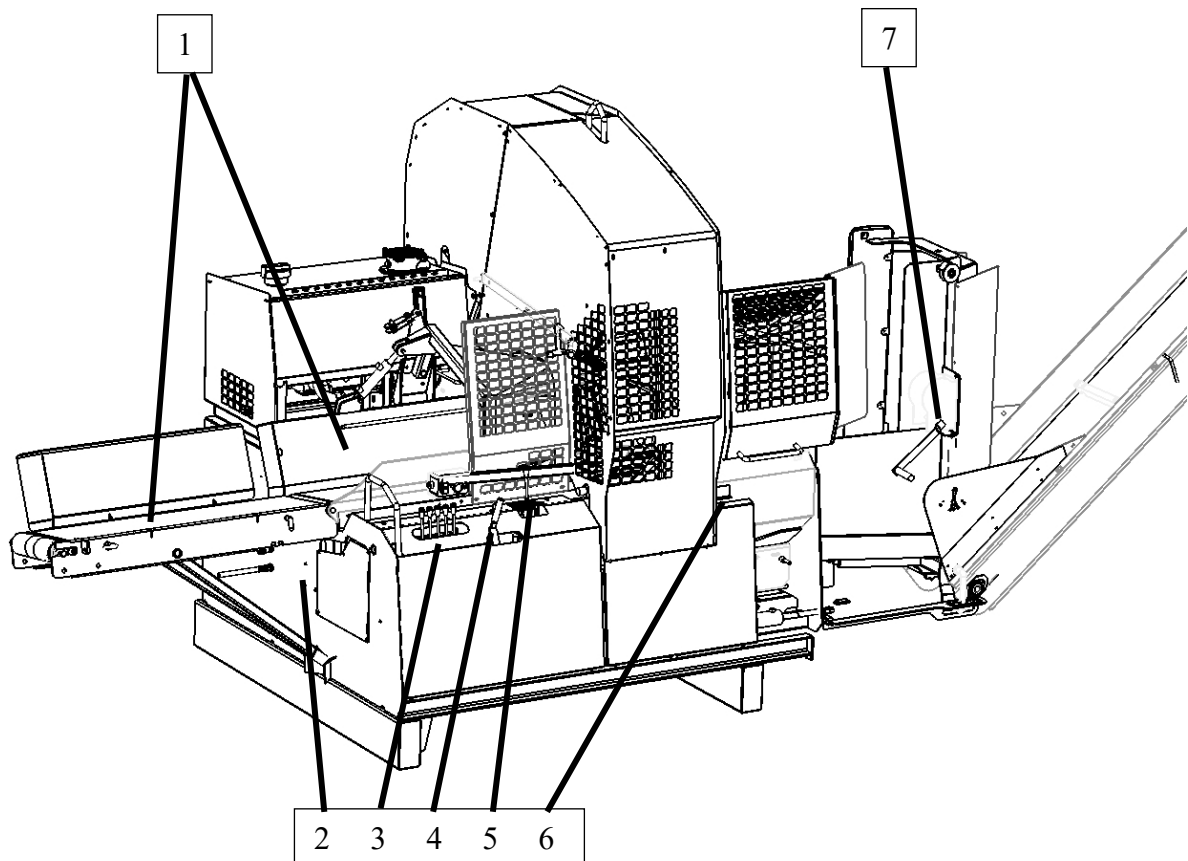

Figure 2

1. Input conveyor and extension
2. Hydraulic power take-off for log deck
3. Operating levers for adjustments of the machine
4. Operating lever, splitting cylinder trigger
5. Operating lever, hydraulic steering of the cutting blade and input conveyor, automatic starting of the splitting cylinder
6. Measurement scale for the Palax Optimi system
7. Conveyor lifting winch

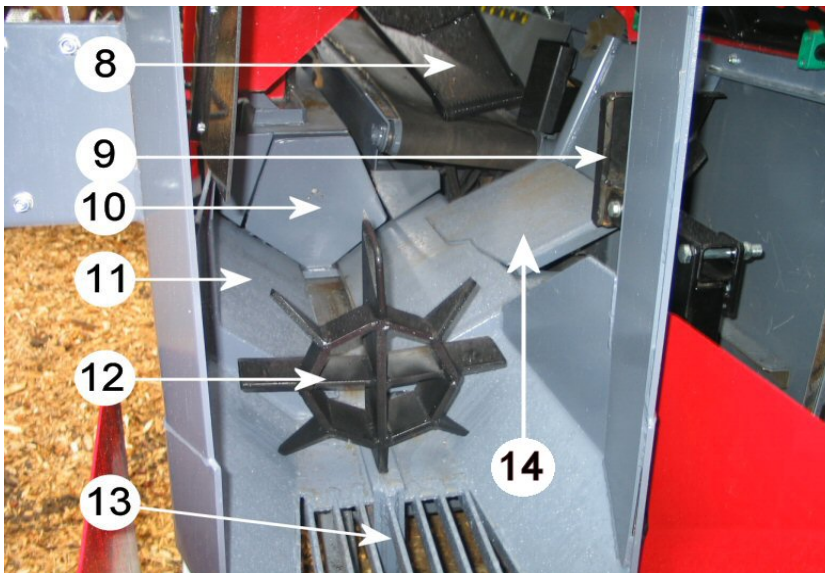

Figure 3

- 8. Wood gripper
- 9. Cutting length limiter
- 10. Buffer
- 11. Splitting groove
- 12. Splitting blade
- 13. Grate
- 14. Guide plate

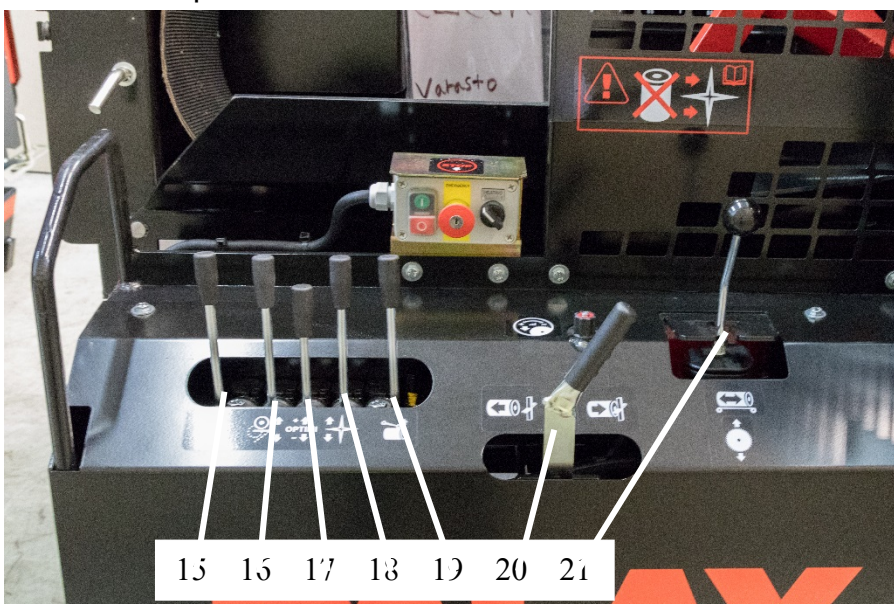

Figure 4

- 15. Log deck steering
- 16. Guide plate
- 17. Cutting length adjustment
- 18. Height adjustment of the splitting knife
- 19. Relief of the wood gripper
- 20. Forced control of the splitting cylinder, 2005 onwards. Path to left/right.
- 21. Control stalk – Steering the main functions of the machine

3 PREPARING THE MACHINE FOR OPERATION AND TRANSPORT

3.1 Extension

Pull handle A on the locking device, turn the extension (figure 5) to the working position, and place the support leg B into slot C.

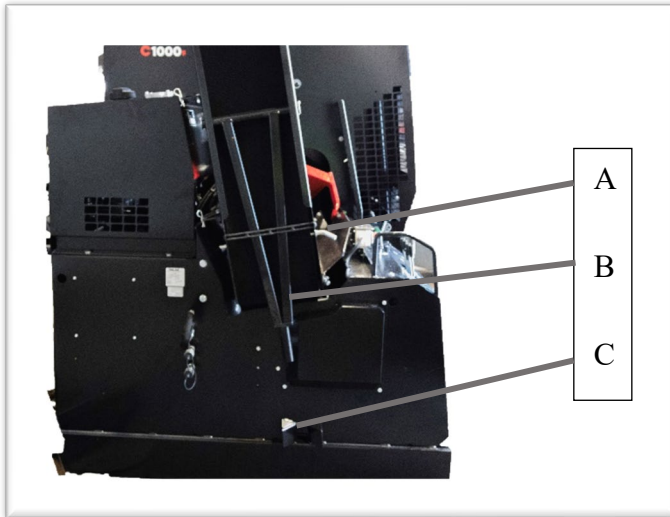

Figure 5

3.2 Adjusting the cutting length limiter

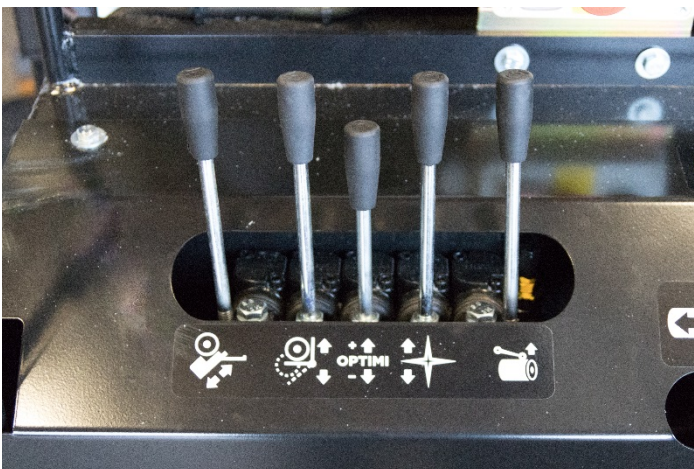

Figure 6

The Palax C1000 is equipped with a *Palax Optimi* cutting length limiter, in which the length of the movement of the splitting cylinder is defined based on the cutting length used. The cutting length is adjusted hydraulically, using the middle adjustment lever in the control levers. There is a measurement scale on the right side of the main frame of the machine, which can be used for reference (figure 6).

3.3 Placing the conveyor in working position



1. Pull down the conveyor so that it rests supported by the winch wires and the front wheel. Remove the conveyor chain holder from below the conveyor.

2. Lower the conveyor using the winch, and lock the conveyor into a straight position using the cotter pins. Adjust the pin clearance using locking pins. The recommendable clearance is 0.5–1 mm.

Figure 7

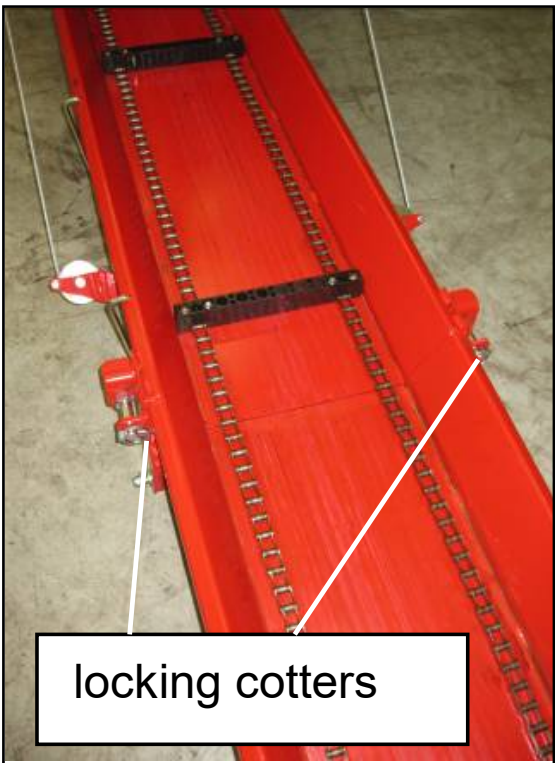

Figure 8

WARNING! Before adjusting the conveyor height, ensure that there are no persons under the conveyor. Always hold on to the winch handle when adjusting the conveyor height.



Figure 9

The machine is equipped with an output conveyor speed adjustment. When you wish to adjust the speed of the conveyor, turn the adjustment valve towards + or -.

3.4 Placing the conveyor in transport position

1. Lower the conveyor using the winch until the front wheel touches the ground.
2. Place the conveyor chain holder in its place.
3. Remove the conveyor locking pins.
4. Lift the conveyor in an upright position against the conveyor support.

4 TRACTOR DRIVE

- Tractor-powered models must always be connected to the tractor drawbar. This is to ensure the distance between the firewood processor and tractor, because if the distance changes during the use of the machine, serious damage may ensue.
- The machine is usually delivered with the fastening lug detached, to be attached by the customer.
- The fastening lug and the equipment required for its installation (figure 10) are delivered together with the tractor-powered machine.



Figure 10

4.1 Installation

1. Install the fastening lug in its place, and insert the M12 locking screw through the inside of the square pipe (figure 11). Place the second screw behind the pipe (not shown in the figure).



Figures 11 and 12

2. Attach the fastener M12, shown in figure 11 below the frame pipe, to the locking screws with two M12 Nylock nuts and two 12 mm washers. Do not tighten.
3. Set the drawbar lug in its place, and attach the screws in their place.
4. Place the lug so that its distance from the centre line of the cardan shaft is in line with the tractor used (figure 13).
5. Then, tighten the M12 nuts which were left untightened in step 2.



Figures 13 and 14

- Always attach the machine to the tractor's lifting gear using the lugs installed in the machine (figure 14).

- Suitable cardan shaft types include BONDIOLI A 143 and WALTERSCHEID W 2300.
- The cardan shaft does not require a safety switch.
- Only use undamaged shafts and attach the guard chains to the machine (figure 15).
- Before using the cardan shaft, ensure that it is properly attached and that sufficient space has been reserved.



Figures 15 and 16

- Support the cardan shaft using the support hook in the machine (figure 16) when detaching the shaft from the tractor.
- The suitable rotation speed range for the cardan shaft is 450–480 rpm.

NOTE! If the machine is moved using a transport chassis, the cardan shaft must always be detached from the machine!

4.2 Emergency stop for a tractor-powered machine

- Tractor-powered models are equipped with a separate quick-stop device, which allows ending the power transmission from the angle transmission to the machine in a moment, stopping the entire machine.
- In an emergency, pull the lever (figure 17) down until the lever is locked and the V-belts are left loose.

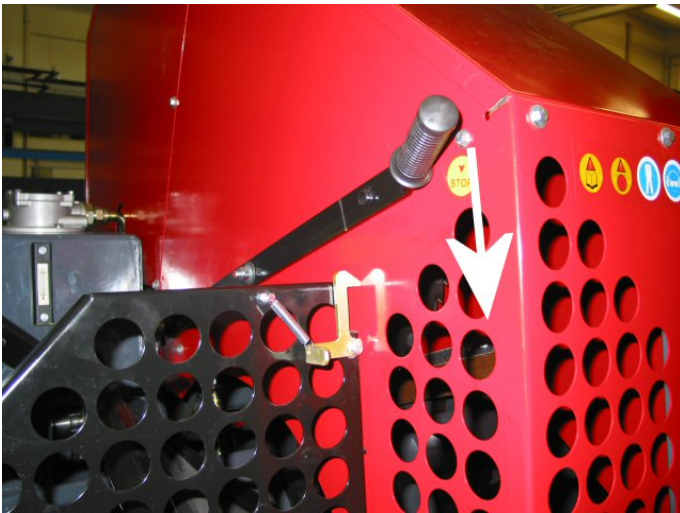

Figure 17

NOTE! Only use the lever in real emergencies, because the V-belts will chafe against the rotating angle transmission's belt pulley, which may cause the V-belts to wear excessively.

4.3 Operation in an emergency

- If the emergency stop device has been used, for example if a log is stuck to the blade due to incorrect sawing, immediately turn off the cardan shaft power transmission from the tractor, as the angle transmission's V-belt pulley may cause unnecessary wear to the V-belts.

NOTE! Turn off the emergency stop device before turning the tractor power transmission back on.

4.4 Moving the machine using a transport chassis (figure 18)

- The maximum towing speed of the Palax transport chassis is 30 km/h. However, country-specific road traffic regulations must always be followed.
- Exceeding the defined maximum speed may cause the hubs of the wheels to break.
- Always ensure before transportation that all moving and lockable parts (including the input conveyor extension and the output conveyor) are locked appropriately.



Figure 18

5. DESCRIPTION OF THE FUNCTION OF THE FIREWOOD PROCESSOR

5.1 Electrical drive, starting and emergency stop

- The motor power is 15 kW and the speed is 1,500 rpm.
- The machine's start function is equipped with an emergency stop.
- All electrical installations are assembled.
- In a 380 V system, the fuse size is 35 A slow.
- A 6 mm² extension cord is required.
- When starting to use the machine, check the rotation direction. If the blade rotates in the wrong direction, switch the positions of the two phase cords in the power cord plug. If you are unsure how to do this, have a professional perform the job.
- The machine is equipped with an automated wye-delta starter.

Emergency stop for an electrically-powered machine:

- Perform the emergency stop by pressing the Emergency stop button.
- The button must be released with a key.

NOTE! If an electrically-powered machine is used in temperatures colder than -15 degrees Celsius, a hydraulic oil such as ISO VG 22 S multi-grade oil or a synthetic hydraulic oil should be used, because the electrically-powered machine will start at maximum rpm.

5.2 Controlling the machine

- Sawing wood, starting the splitting, and using the input conveyor are all controlled hydraulically using one lever (21, figure 4).
- For a description and pictures of the controls, please refer to chapter 2.4.
- When the operating lever is in free position, the blade actuating cylinder and input conveyor motor are pressure-free.

Input conveyor forward:

- Push the lever up and to the right to start the input conveyor feeding the log.

Input conveyor reverse:

- Push the lever up and to the left to start the input conveyor reversing.

Log cutting:

1. Pull the lever down, and the cutting blade will saw the log.
2. Push the lever up to lift the cutting blade back up.
3. Splitting will start automatically when the blade is lifted.

5.3 Using the firewood processor, sawing wood

- The machine is intended to be used by one person at a time.

- Never leave a ready-to-use machine unattended.

5.4 Using the cutting blade, before sawing

Clean the new blade of any protective grease, because a greasy blade may gather resin and overheat, which will cause it to lose its tension and be deformed.

5.5 During sawing

- Be very careful and always keep your hands away from the blade.
- Never stop the blade by pressing it into the log.
- When sawing, always ensure that the sawing point of the log corresponds to the support roll and drive roller.

5.6 Setting log on the table

- Set the log on the table so that it meets the wall behind the conveyor. Otherwise, it may move during sawing.
- Exercise extreme caution when sawing curved logs.

WARNING! Due to the sawing power, curved logs may rotate on the table, twisting the blade and breaking it.

5.7 Sawing logs

- Pull the hydraulic valve operating lever back to lower the cutting blade and saw the log.
- Exercise extreme caution when sawing curved logs or logs with branches.



Figure 19

- The machine is equipped with cutting blade lowering speed adjustment. If you wish to make the lowering speed of the cutting blade slower or faster, turn the valve towards + or -.

5.8 Sawing the last log

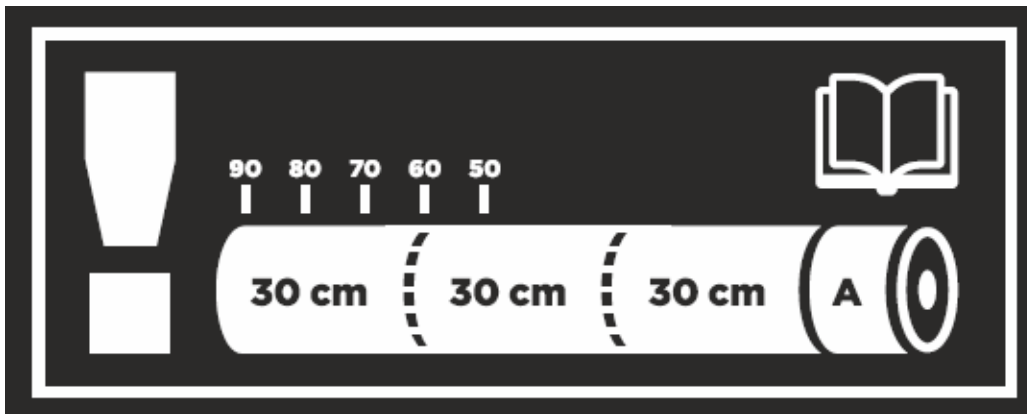

Figure 20

- Cut off the undersized piece while there is still sufficiently material for two or three more pieces of appropriate size left in the billet. The last log must not be longer than the adjusted cut-off length.
- Use the scale at the edge of the in-feed deck as an aid, Fig. 20.

5.9 Feeding the last log for splitting

- Drive the last log through the blade over the guide plate (figure 3), and drop it to the splitting groove for splitting (figure 4, lever 16). Start splitting manually (figure 4, lever 20) after ensuring that the log is in the correct position.
- A measurement scale for sawing the evening piece is located over the input conveyor.

5.10 Disturbances in sawing and solving them

Curved logs:

- Saw curved logs along the curves.
- When sawing curved logs, ensure that the log corresponds to the support roll.

Large logs:

- If the sawing sound is soft, the speed and blade rotation speed are correct.
- If the sawing sound is strong and abrupt, the blade feeding to the log is too strong and the sawdust grooves may be blocked. Check the rotation speed and the sharpness of the blade.
- If the log gets stuck to the blade due to incorrect sawing, stop the machine immediately.
- Check the stuck blade before sawing. Some of the blade's teeth may be broken at their root.
- Do not saw using a damaged blade.

6. USING THE FIREWOOD PROCESSOR, SPLITTING WOOD

6.1 Splitting cylinder

- A 16-tonne actuator cylinder can be installed into the machine using either the standard cylinder or a PowerSpeed cylinder.

6.2 Splitting blades

Standard equipment blade:

- A 2/6 blade, allowing logs to be split into two or six parts.

Accessory blades:

- Short straight blade, which splits the log into two parts, or if the blade is lowered, the log is not split.
- A 2/8 blade, allowing logs to be split into two or eight parts. Usually requires a 10-tonne cylinder.
- A 2/10 blade, allowing logs to be split into two or ten parts. Usually requires a 16-tonne cylinder.
- A 2/12 blade, allowing logs to be split into two or twelve parts. Usually requires a 16-tonne cylinder.

6.3 Splitting blade height adjustment

- The machine is equipped with hydraulic splitting blade height adjustment.
- The blade can be adjusted up or down during working.

6.4 Disturbances in splitting and solving them

Stuck log:

- In case of large logs with large branches, the cylinder power may not be enough, in which case the log may be stuck to the blade. Remove the log as follows:
 1. Return the cylinder manually.
 2. Lift up the splitting blade and try splitting manually. Turning the log into a different position often helps.
 3. If the log does not split, open the guard and hit the stuck log with another log so that it comes loose.
 4. If the log has a large branch, position the log with the base end facing the blade, which allows the large branch to be split with the minimum amount of power.

Log fallen into incorrect position in the splitting groove:

- If, for some reason, a log falls upright after sawing, you can prevent splitting by pushing the splitting forced control lever (figure 4, lever 20) to the left while lifting up the blade. Automatic splitting will not start.
- Correct the position of the log and start splitting manually by pushing the splitting forced control lever to the right.

6.5 Safely resplitting logs

- If you need to make small firewood from a large log, the pieces which have been split once may be too large.
- Below are the instructions for safely resplitting the firewood.
 1. Open the guard.
 2. Place the logs to be split into the splitting groove, for example two pieces over each other. Grab them lightly to the blade to keep them in place.
 3. Close the guard.
 4. Start splitting using the forced control lever.

7 MACHINE MAINTENANCE

NOTE! Always stop the firewood processor and disconnect it from its power sources before performing any maintenance procedures.

NOTE! In order to clean the buffer guides, drive the Palax Optimi to its extreme position (55 cm) once a day, and return it to the required sawing position.

7.1 Replacing the cutting blade, figure 21

1. Remove the attachment screws of the protective casing with a 13 mm key.
2. Turn back the large protective casing.
3. Open the blade nut using the special key delivered with the machine. Thread right-handed, key 36 mm.
4. Remove the cutting blade.
5. Clean the surfaces of the saw bars carefully.
6. Lift the new blade into place.
7. Ensure that the cotter bolt which prevents the saw bar from turning is in its place before installing the saw bar.
8. The guide bit clearance from bit to blade must be at least 5 mm.
9. Attach the blade and protective casing.



Figure 21

7.2 Sharpening the blade, hard-metal blade

- Hard-metal blades can be lightly sharpened using a diamond file.
- Depending on the cleanness of the wood, the sharpening of a hard-metal blade may last for up to 500-1,000 steres.

- The best result and durability of the blade are achieved when the blade is sharpened in an appropriate grinder and diamond grinding wheel.

7.3 Tensioning the blade, hard-metal blade

- Problems related to tensioning are not common in hard-metal blades. However, if a particularly dull blade is used, it may overheat, causing a problem in the tensioning.
- The blade should be tensioned by a professional.

7.4 V-belt tensioning, angle transmission/middle shaft

- The Palax C1000 is equipped with automated belt tensioners.

7.5 V-belt tensioning, middle shaft/blade shaft V-belt tensioning

- The Palax C1000 is equipped with automated belt tensioners.

7.6 Replacing V-belts, angle transmission/middle shaft

1. Remove the rear guard plate.
2. Remove the oil pump fastening flange (4xM10 screws, key 17 mm).
3. Loosen the belts by turning the tensioner away.
4. Remove the old belts and replace with new ones.
5. Release the tensioner to let it tighten the belts correctly automatically.
6. Install the rear guard plate.

7.7 Replacing V-belts, middle shaft/blade shaft

1. Remove the attachment screws of the protective casing with a 13 mm key.
2. Turn back the large protective casing.
3. Remove the cutting blade. Open the blade nut using the special key delivered with the machine. Thread right-handed, key 36 mm.
4. Loosen the belt tensioner.
5. Replace the belts.
6. Clean the surfaces of the saw bars carefully before installing the blade.
7. Ensure that the cotter bolt which prevents the saw bar from turning is in its place before installing the saw bar.
8. Attach the protective casing.

7.8 Tightening the input conveyor belt

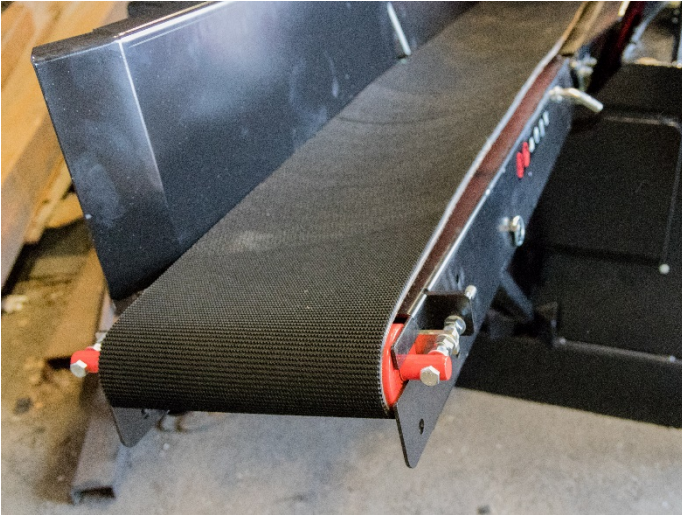

Figure 22

- The end of the input conveyor extension has tightening screws for tightening the belt.
- When tightening the belt, ensure that it runs in the middle of the roller.

7.9 Replacing the input conveyor belt, figure 23

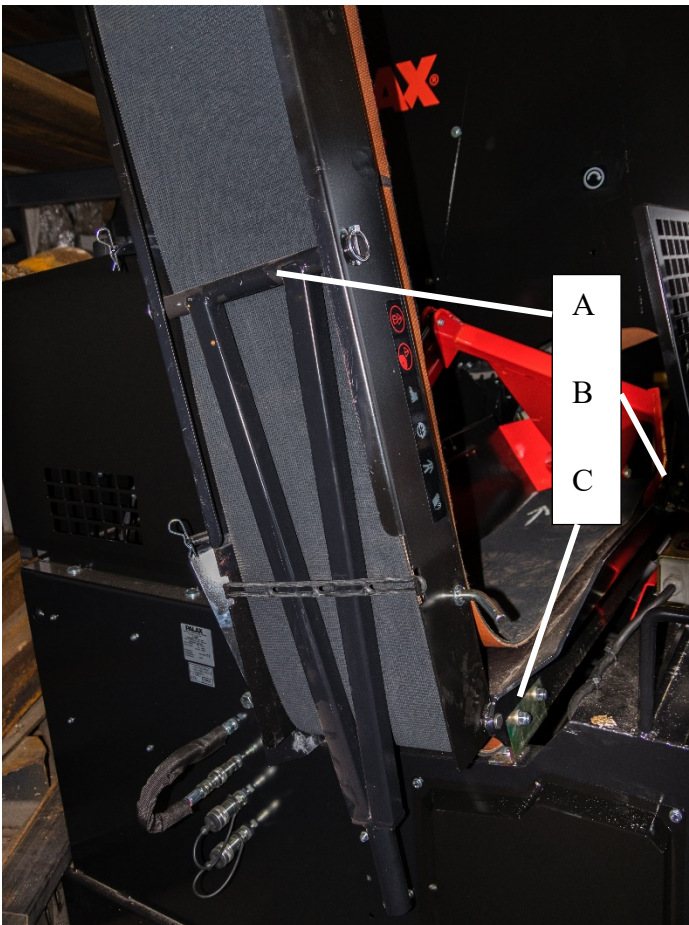

Figure 23

1. Turn the input conveyor extension into transport position.
2. Remove support leg A.
3. Remove the lower bearing block on the wood gripper, to allow turning the gripper to the side (B).
4. Remove spacer plate C, located on the lower side of the conveyor, on the left end of the input conveyor. It is attached with three bolts.
5. Remove cover plate C, attached with two bolts, from the side of the splitting groove.
6. Replace the old belt with the new one, and attach the bearing block, spacer plate, cover plate, and support leg.

7.10 Changing the oil of the angle transmission

1. Open the oil filler cap and remove the old oil.
2. Add the new oil (approximately 0.9 l).

7.11 Changing hydraulic oil

- The normal amount of hydraulic oil is 160 litres.
- Oil quality ISO VG 32; e.g. Unavis 32, SHELL Tellus 32, NESTE HYDRAULI 32, or equivalent.
- Continuous work in warm conditions: ISO VG 46.
- When using an electric motor in cold conditions, multi-grade oil such as ISO VG 22 S or a synthetic hydraulic oil should be used, because the electrically-powered machine will start at maximum rpm when started cold.
- Be extremely careful with the cleanness of the oil when changing the oil, because the operation of the machine depends on clean oil.

7.12 Lubrication of the machine

- Middle shaft and blade shaft ball bearings Lubrication interval approximately 500 hours and always when the machine is left unused for a longer period of time, in order to have new lubricant to protect the bearings efficiently from moisture and rusting.
- Operating lever ball bearings, blade operating lever articulation bearings 200 hours and always when the machine is left unused for a longer period of time, in order to have new lubricant to protect the bearings efficiently from moisture and rusting.
- Joints in the length limiter, infeed table support roll, and the infeed table once a week with sprayable Vaseline.
- Hydraulic valve lock ends and swivel heads after 80 hours.



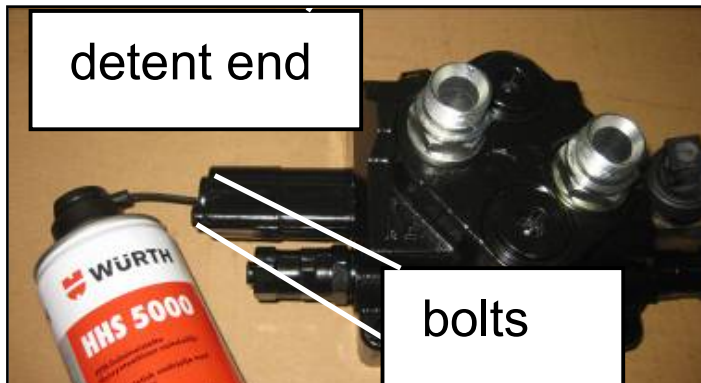

Figure 24

Figure 25

1. When opening the detent end, first open the screws of the protective casing and remove the casing.

2. When the protective casing has been taken off, the valve must not be moved to avoid the balls inside the retainer bushing from being

removed from their place and being lost.

3. Spray a generous amount of CRC-type lubricant into the lock end.
4. Attach the protective casing.

- Lubricant can also be sprayed into the lock head through the hole in its end.
- Use the same Vaseline for the swivel heads as for the ball bearings.

7.13 Tensioning the conveyor chain of the conveyor

- The conveyor has hydraulic motor drive and automated chain tensioning.

NOTE! When you place the conveyor in working position, ensure that the lower end of the chain lies over the drive roller, and the upper end on the tensioning roller.

7.14 Cleaning the conveyor

- Keep the conveyor clean of any debris in order to ensure uninterrupted operation.
- Cleaning the conveyor is particularly important in wintertime, when the use of the machine is stopped.
- The conveyor can also be washed with a pressure washer, but the conveyor chain must be lubricated after washing.

7.15 Washing the machine

- Wash the machine with a pressure washer periodically. This is particularly important when the machine is left unused for a longer period of time. Lubricate the machine after washing.

NOTE! Do not aim the water jet directly at the electrical equipment or bearings.

7.16 Storage of the machine

- Although the machine is intended for outdoor use, it should be covered and stored in a sheltered location or indoors during longer periods of not being used. This way, you can avoid unnecessary corrosion and malfunctions.

8 MAINTENANCE TABLE

Target	Task	Daily	Interval hours	Substance/accessory item
Angle gear	Check 1st change 2nd change		100 500 1,000	SAE 80 0.9 l
Hydraulic oil	Check 1st change 2nd change		X 500 1,000	Hydraulic oil (x) ISO VG 32
Oil filter	Check 1st change 2nd change		500 1,000	FIO 180/3
All ball bearings	Lubrication		500 or monthly approx. 2 doses	Ball bearing Vaseline
All levers	Lubrication	X		Lubrication oil
Machine	Clean	X		
Hydraulic valve lock ends and swivel heads	Lubrication		80	See instructions at 7.12

x.) Continuous use in warm conditions: ISO VG 46. Electric motor drive in cold conditions (below -15 degrees Celsius): ISO VG 22 S multi-grade oil.

9 FAILURES AND REMEDIAL MEASURES

Failure	Cause	Remedial measure
The speed of the cutting blade decreases during sawing.	<ol style="list-style-type: none"> 1. The blade is dull. 2. The V-belts are too worn. 	<ol style="list-style-type: none"> 1. Sharpen the blade. 2. Replace the V-belts.
The cutting blade begins to sway after a short sawing period.	<ol style="list-style-type: none"> 1. The blade is dull and overheats, causing a tensioning error in the blade. 	<ol style="list-style-type: none"> 1. Sharpen the blade and check the tensioning.
The blade makes a whistling noise.	<ol style="list-style-type: none"> 1. Rpm too high; max 1,000. 2. Breakage in the blade. 	<ol style="list-style-type: none"> 1. Lower the speed. 2. Use forbidden.
The blade runs in an incorrect direction.	<ol style="list-style-type: none"> 1. The current phase of the electric motor is incorrect. 	<ol style="list-style-type: none"> 1. Switch the positions of the two phase cords.
The electric motor stops easily.	<ol style="list-style-type: none"> 1. The blade is dull. 2. The thermal relay is incorrectly installed. 	<ol style="list-style-type: none"> 1. Sharpen the blade. 2. Install the thermal relay correctly.

10 ELECTRICAL DIAGRAMS

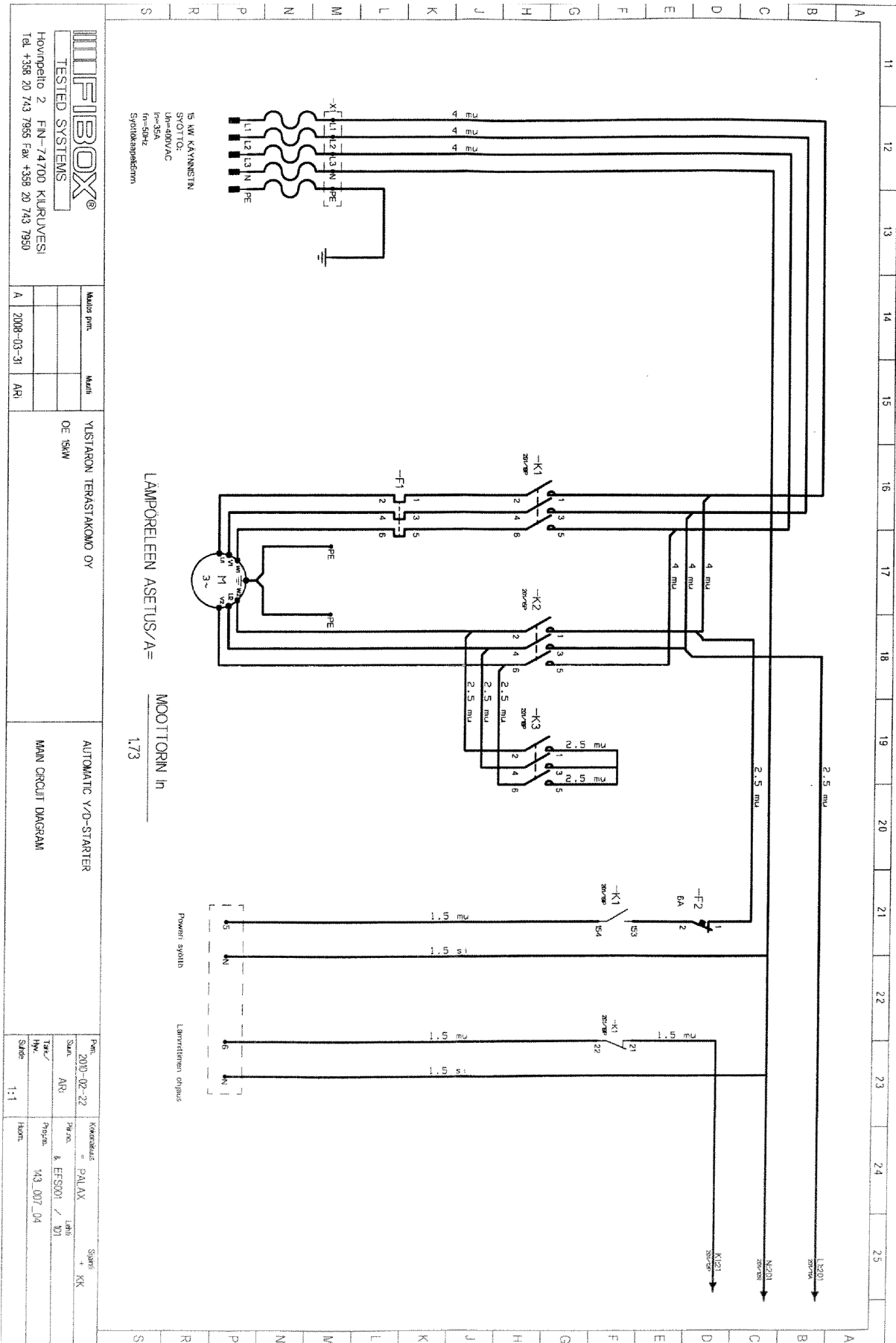

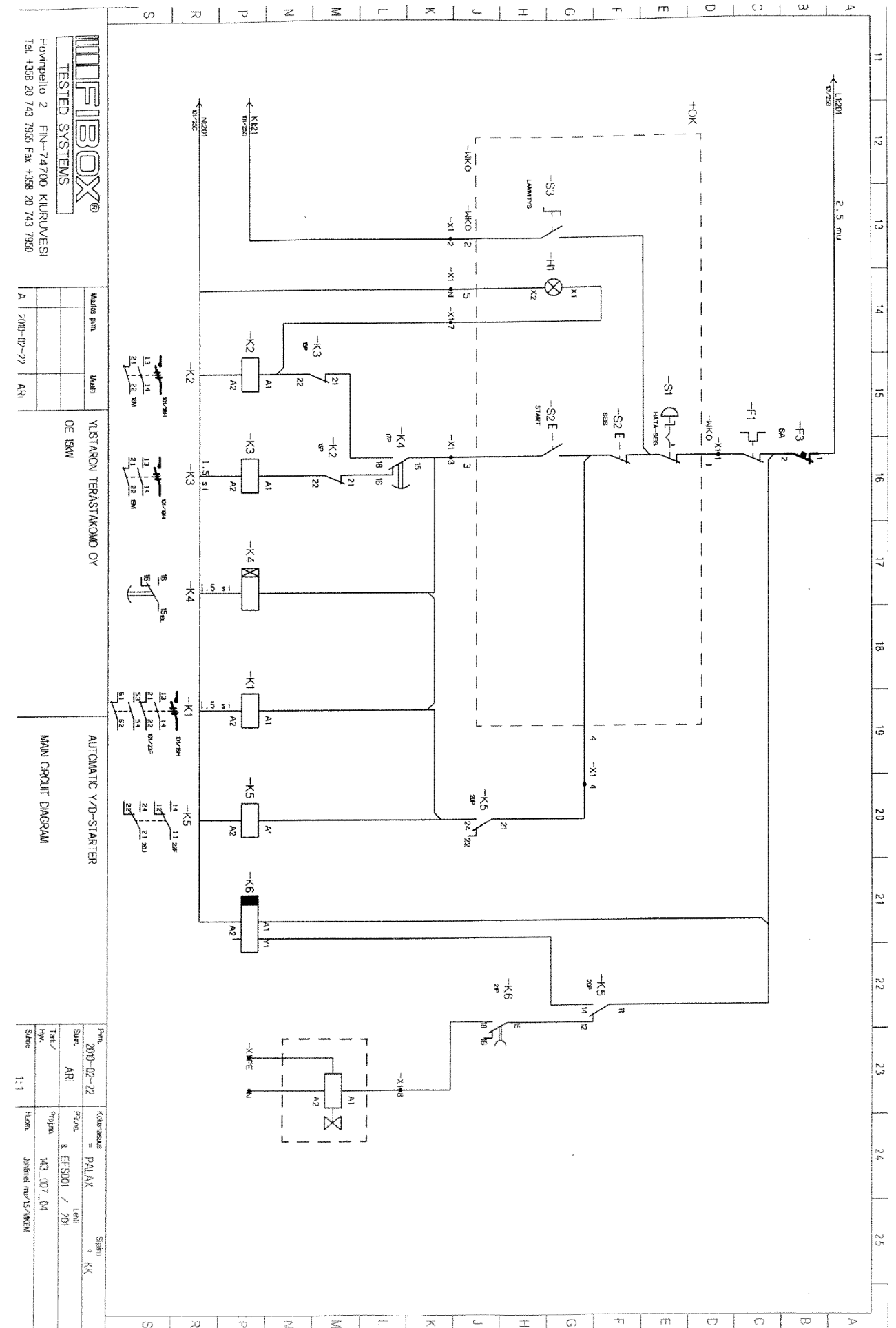

MPEIBOX
TESTED SYSTEMS

Hovvopello 2 FIN-74700 KURJUVESI
Tel. +358 20 743 7955 Fax +358 20 743 7950

Määrös pvm.	Malli

YLISTARON TERÄSTAKONO OY
OE 15KW

AUTOMATIC V/D-STARTER
MAIN CIRCUIT DIAGRAM

Pvm.	2019-02-22	Kokonaissuunnitelma	Sisältö
Suunn.	ARI	= PALAX	+ KK
Tark./		Projekti	
Hv.		& EFSUO1 / 201	
Skala		M3_007_04	
Storlek	1:1	Yhteyden otus/TEKNI	