

User manual Palax Mega

Always study this manual before operating the machine.

Serial number _____

Year of manufacture _____

PALAX
Lahdentie 9
FI-61400 Ylistaro, FINLAND
Tel. +358 6 4745100
Fax. +358 6 4740790
www.palax.fi

TABLE OF CONTENTS

1	Declaration of incorporation for partly completed machinery	2
2	Introduction	3
3	General safety instructions	4
4	Palax Mega – log deck assembly instructions	5
4.1	Delivery package	5
4.2	Required tools	5
4.3	Assembly	6
4.4	Hydraulics	12
4.5	Connection to a firewood processor	12
5	Operating the Mega log deck with a firewood processor	13
5.1	General	13
5.2	Control	13
6	Type plates, main measurements and warning labels	14
6.1	The machine’s type plate	14
6.2	The machine’s main measurements	15
6.3	Warning labels	15
7	Maintenance table	16
8	Failures and remedial measures	16

1 Declaration of incorporation for partly completed machinery

Manufacturer: Ylistaron Terästäkomo Oy

www.palax.fi

Lahdentie 9

FI-61400 Ylistaro

Finland

+358 6 474 5100

Person responsible for the technical file: Kai Koskela, kai.koskela@palax.fi

Product: Palax Mega

Log deck, firewood processor accessory

Driving power: Auxiliary hydraulics valve of the firewood processor

Serial number: _____

We hereby declare that this machine meets the requirements concerning the safety of machinery specified in Government Decree 12 June 2008/400, which was instituted to bring into force Machinery Directive 2006/42/EC. We undertake to supply the necessary technical documents concerning partly completed products to national authorities upon request with the proper grounds. This partly completed machine may only be connected to a suitable Palax firewood processor that meets the requirements of the effective legislation and the Machinery Directive.

Ylistaron Terästäkomo Oy

4 March 2019



Pekka Himanka

Managing Director

2 Introduction

This manual is intended for operators with the appropriate expertise. The operator is required to have the general knowledge and skills needed in normal situations. For example, a person purchasing a tractor-powered machine is expected to be able to operate the tractor's cardan shaft drive.

Study the manual thoroughly before installing the machine and beginning operation. In addition, familiarise yourself with the controls and the emergency stop mechanism before operating the machine. Additional information on our company's products is available on our website at www.palax.fi.

Register yourself as the owner of the machine at <https://info.palax.fi> in order to ensure that you have access to the latest information on the machine.

NOTE! Always keep this manual in the immediate vicinity of the machine.

3 General safety instructions

Palax Mega is a log feeding accessory for firewood processor models Palax KS35, KS43s, Palax C750, Palax C900 and Palax C1000.

This machine is intended to be used connected to a firewood processor. Therefore, the safety provisions in the firewood processor's manual also apply to this machine.

Drive the device with the firewood processor's hydraulics valve; do not connect it to the tractor's hydraulics, for example.

Before using the machine, familiarise yourself with the operation of both the log deck and the firewood processor. You must also understand how the machine works and be aware of the risks involved. All safety instructions concerning the firewood processor also apply to the Palax Mega log deck.

Always use the feeding device with extreme care so as to avoid injuring yourself or other people in the vicinity or damaging the machine.

Persons under 18 years of age are not allowed to operate the machine!

Do not feed more than one log at a time.

During operation, other people or items or equipment that may be damaged must not be in the vicinity of the machine. The safety area around the deck is 10 metres.

4 Palax Mega – log deck assembly instructions

4.1 Delivery package



4.2 Required tools

- 19 mm wrench, 2 pcs
- 22 mm wrench
- 24 mm wrench
- 27 mm wrench
- 30 mm wrench, 2 pcs
- 5 mm Allen key

4.3 Assembly

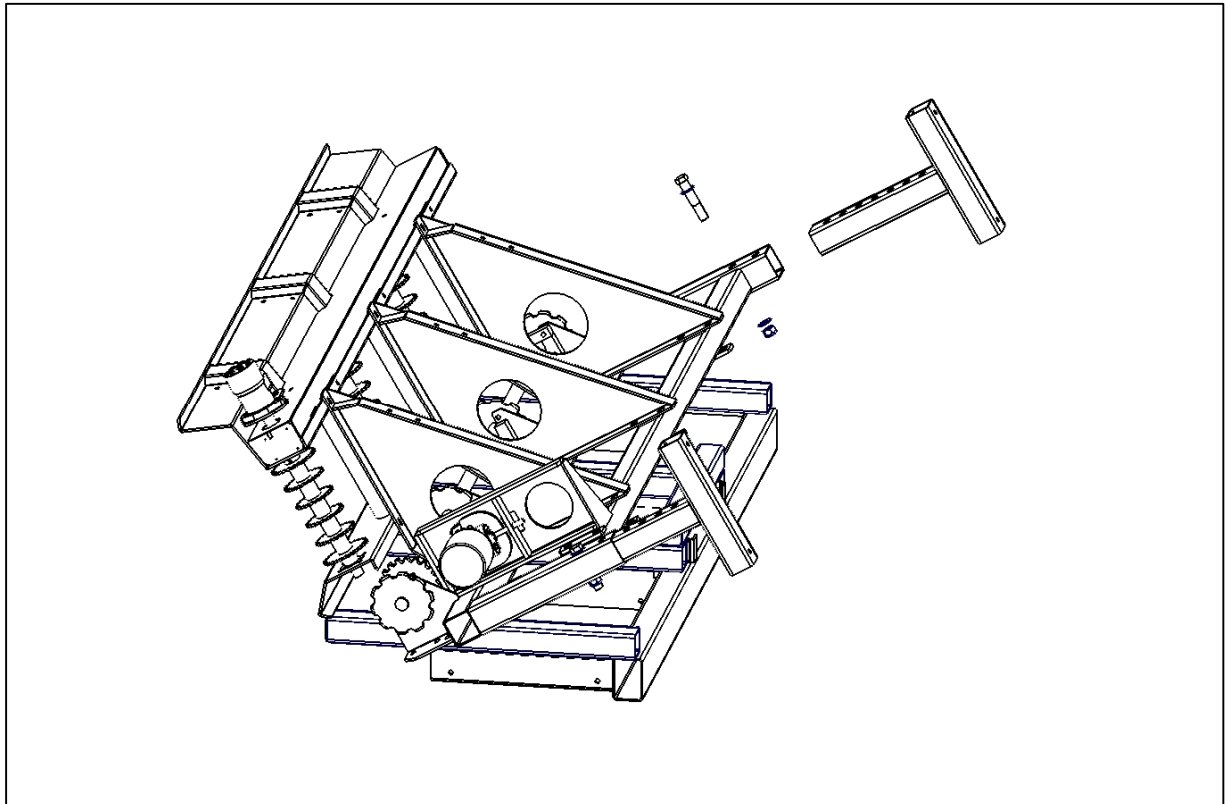

- Attach the T-legs of the roller conveyor with M12 x 100 screws.

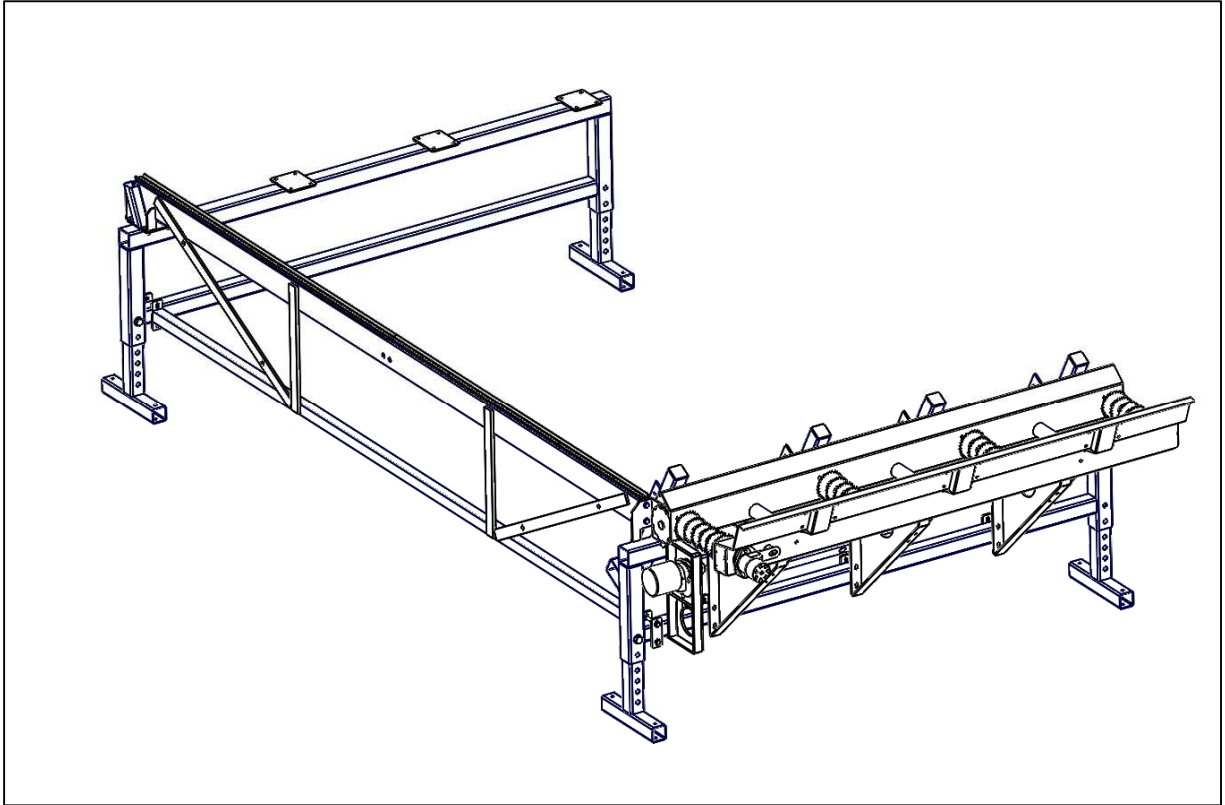

- Attach the T-legs of the rear section's connecting beam with M20 x 100 screws.
- Lift the roller conveyor and the connecting beam to a position where they connect with each other, and lift the bearer in place.

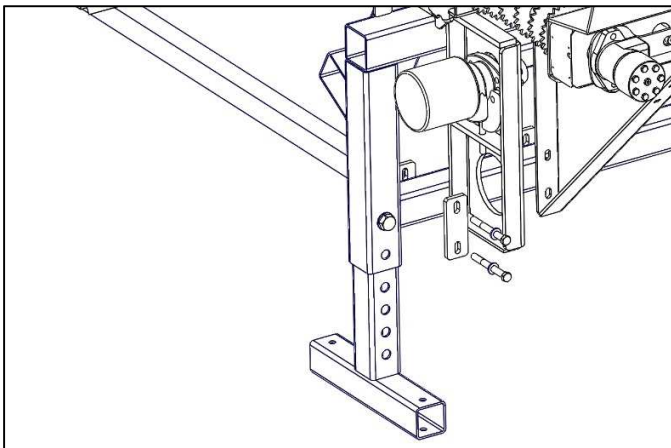

- Fasten the bearer with M12 x 120 screws at the roller conveyor end.

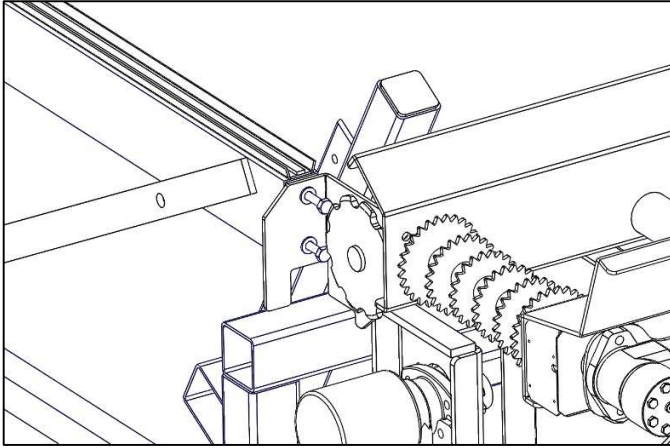

- Fasten the upper end of the bearer with M12 x 35 screws.

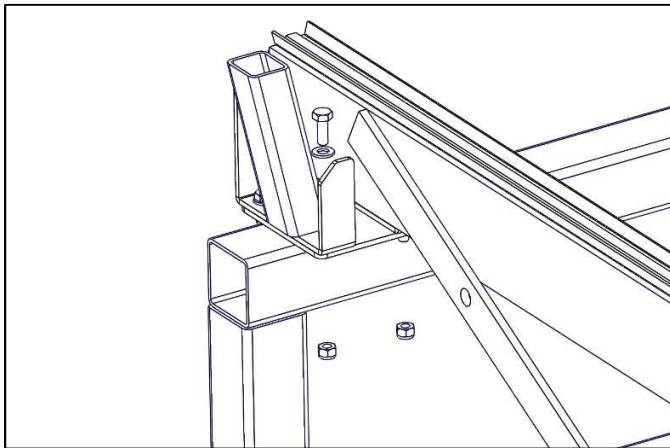

- Fasten the bearer to the connecting beam; 4 pcs of M12 x 45 in the upper section, M12 x 120 in the lower section (as in the front).

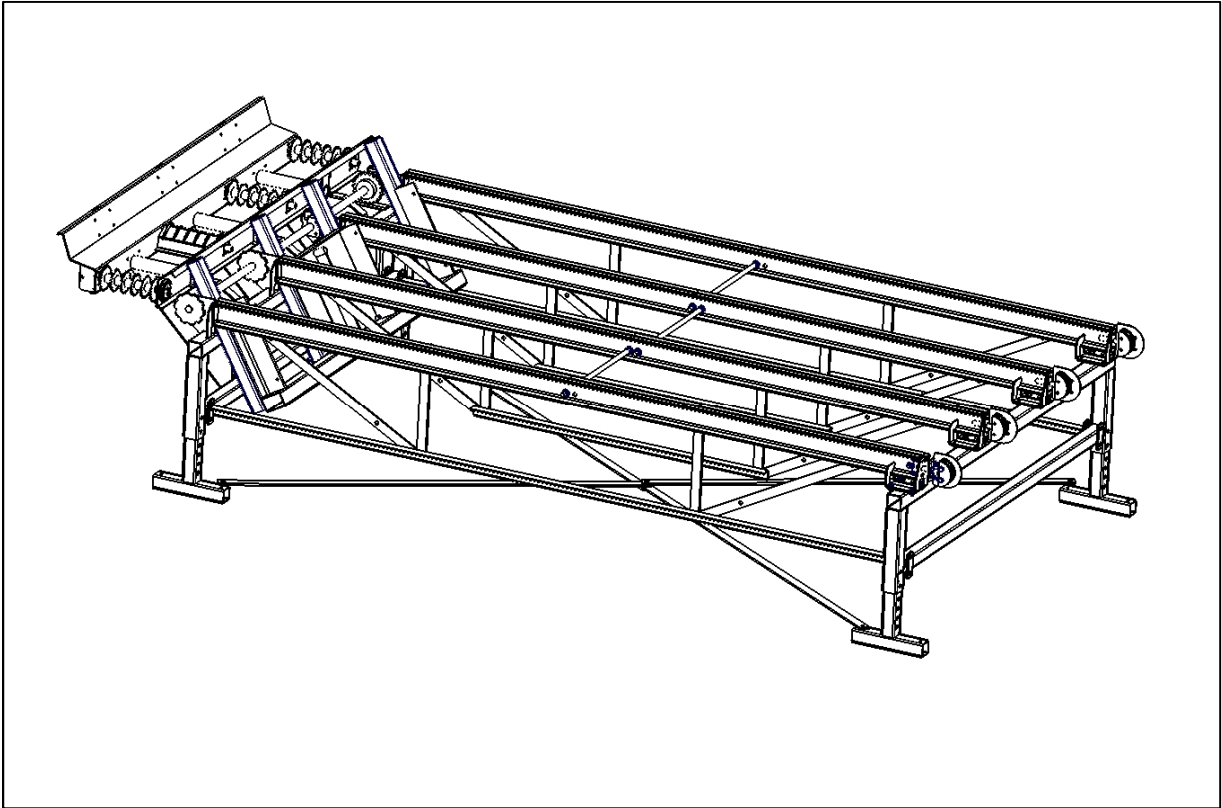

- Fasten all bearers in their correct positions. The outermost bearers must be attached through the upper and lower section. Only fasten the two middle bearers through the upper section.

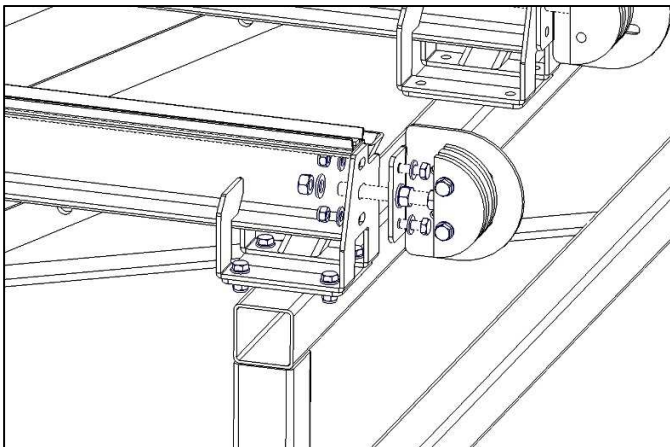

- Fasten the chain sheaves with M12 x 35 screws. Do not tighten the plastic parts yet.

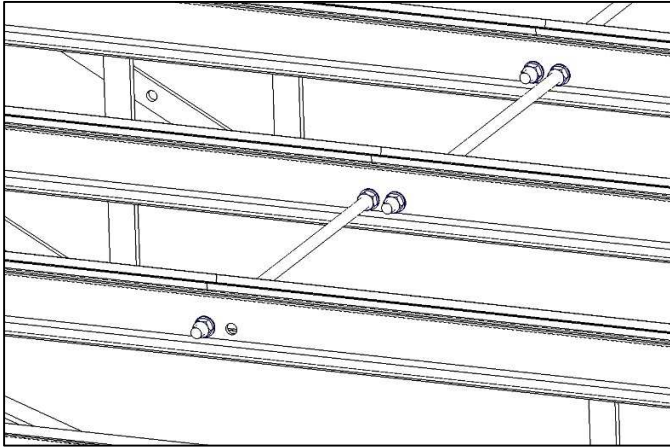

- Connect the bearers to each other with threaded rods. Lock the threaded rods in place with bolts on both sides of the bearer.

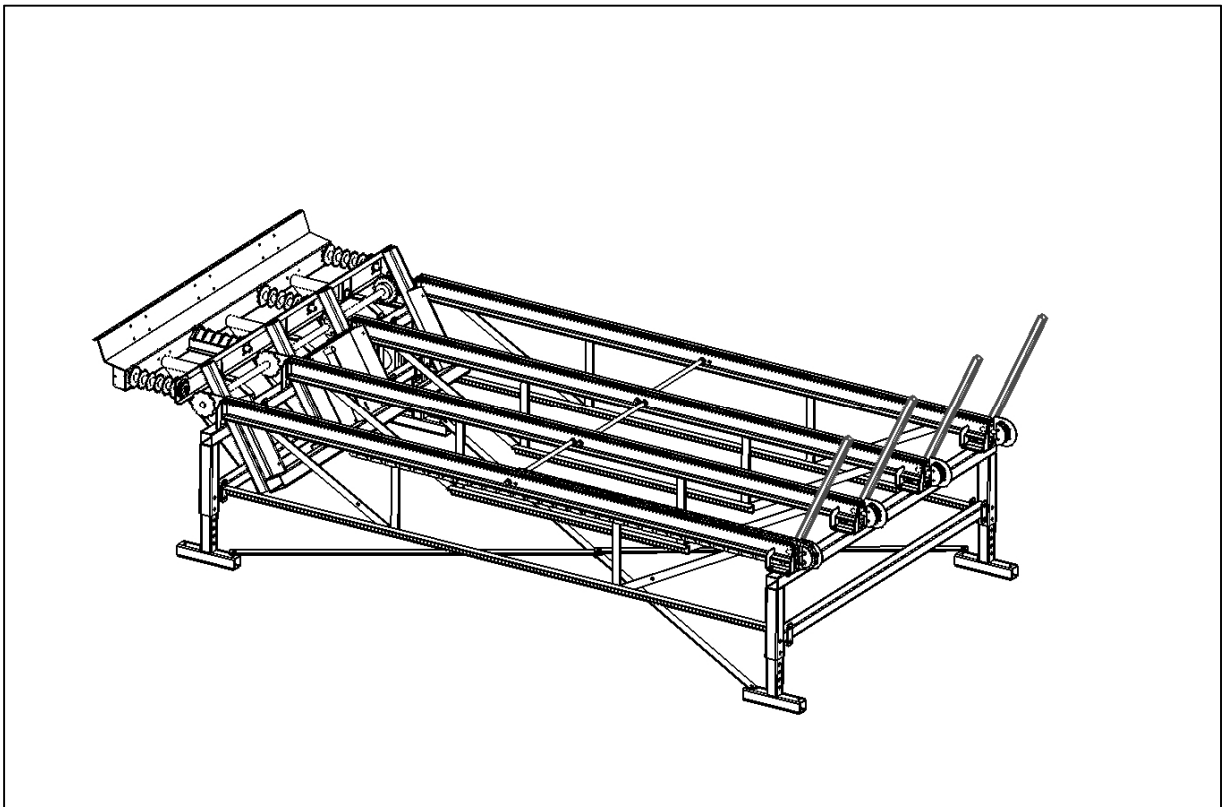

- Lift the chains onto the bearers, and connect the chain ends with a connecting link.
- Once the chains are in place, install the vertical brackets.

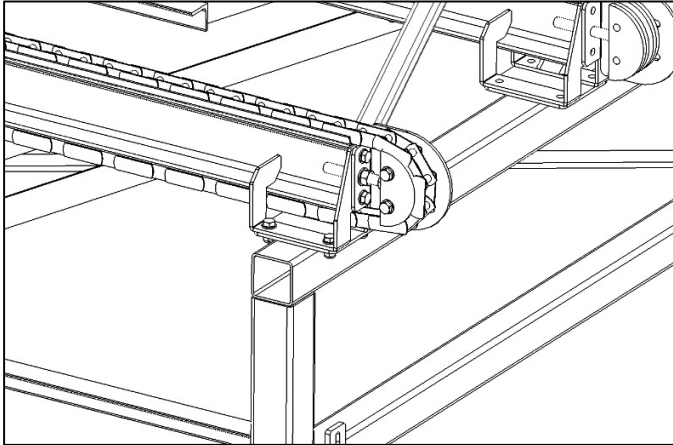

- Tighten the chain at the sheave end in such a way that the middle sags no more than 5 cm in relation to the bottom surface of the beam.
- Once the chain is at the suitable tightness, tension the sheave end with M8 x 80 screws.

4.4 Hydraulics

The hydraulics assembly of the Mega log deck has been installed at the factory. The deck is ready for connection to the firewood processor by means of quick couplings.

When connected correctly, the feed rollers rotate in the same direction simultaneously with the firewood processor's feed belt. If the conveyor rollers rotate in a different direction than the firewood processor's feed belt, the positions of the hoses connected to the roller conveyor's hydraulic motor must be swapped.

4.5 Connection to a firewood processor

The Mega log deck is connected to the firewood processor with quick couplings. The in-feed conveyor is connected to the machine's "hose loop" with 3/8" male and female quick couplings. The chain conveyor is connected with 1/2" quick couplings. The couplings can be connected either way to determine the running direction based on the position of the deck in relation to the machine. The couplings are located at the in-feed conveyor end of the firewood processor – at the end of the machine or inside it, depending on the model.



5 Operating the Mega log deck with a firewood processor

5.1 General

- Ensure that the working surface is flat and firm beneath the Mega deck. You can adjust the alignment and height of the machine with the adjustable legs.
- The correct height is adjusted based on the firewood processor's log holder. The deck's feed roller and the firewood processor's log holder should be at the same height.
- In order to avoid feed malfunctions, you should sometimes reverse the deck to even out the log stack.
- When loading logs onto the deck with a loader, ensure that the logs are straight and move freely on the bearers. If this is not the case, you must reload the logs.
- The logs must be loaded in such a way that the distance the log runs over the bearer is equal on both sides.
- Note! Do not feed logs into the firewood processor at the same time that logs are being deposited on the deck with a loader.
- The distance between the deck's feed rollers and the feed belt depends on the length of the log to be sawn. The distance between the log being fed and the feed belt must be at least 20 cm when the discs roll the log to the feed rollers.

5.2 Control

The Mega deck is operated with a hydraulic valve via the firewood processor's control panel.

- The in-feed conveyor is connected in series with the hydraulic motor of the firewood processor's conveyor belt. The in-feed conveyor runs when the firewood processor is used to feed timber to the machine.
- The chain conveyor is controlled with a hydraulic valve. The chain running direction and the operation of the log lifter are dependent on the hose connections.
- When the valve lever is turned, the chain conveyor moves the logs towards the feeder. Once the log is on the feeder, the valve is released.
- When the valve is moved in the opposite direction, the feeder lifts the log onto the roller conveyor. Once the feeder is in the upper position, the chain conveyor begins to run backwards. The motion stops when the valve is released.

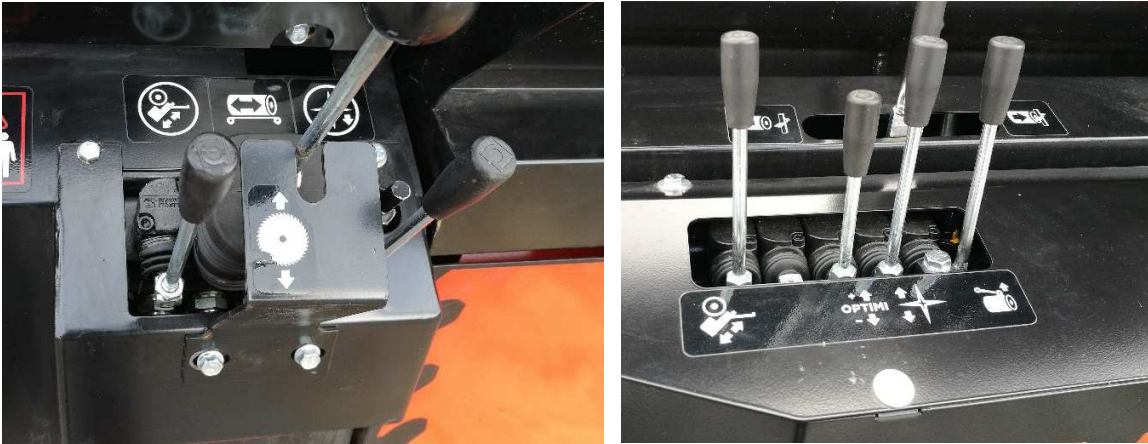

- Control of the log table as it appears in varying control panels. The controls are marked on the log deck with illustrative symbols.

6 Type plates, main measurements and warning labels

6.1 The machine's type plate



- ❑ Name and address of manufacturer
- ❑ Machine type
- ❑ Production number and year
- ❑ Machine weight
- ❑ The plate is on the chain guard of the machine's in-feed disc.
- ❑ Indicate the production number and year when ordering spare parts.



6.2 The machine's main measurements

Weight	1,080 kg
Height/width/length	1,500 x 2,458 x 5,250 mm
Max. log diameter	43 cm / see firewood processor restrictions
Max. Log length	5 m / see firewood processor limitations
Max. load on deck	Approx. 10 m ³ , depending on the wood

6.3 Warning labels

	
<p>Only one person may operate the machine</p>	<p>Beware of the moving feeding equipment.</p>

7 Maintenance table

Target	Task	Daily	Interval 100 h	Interval 500 h	Interval 1,000 h	Substance/accessory item
Machine	Cleaning	X				
Chain beam chains	Lubrication		X			Vaseline spray
Chain beam/feed roller bearings	Grease nipple lubrication			X		Vaseline

8 Failures and remedial measures

Failure	Cause	Remedial measure
The feed roller does not move.	1. The connectors between the machines are disconnected.	1. Connect the connectors.
The chain conveyor does not move.	1. The connectors between the machines are disconnected. 2. The hydraulic motors are incorrectly connected.	1. Connect the connectors. 2. Check the motor connections.
The feed rollers rotate in the wrong direction.	1. The direction of the motor hoses is incorrect.	1. Reverse the hoses.
The logs are jammed on the deck.	1. The deck has been loaded incorrectly.	1. Load the deck again.

